

Assembly Instructions for cable gland: 501/453 Exd IIC/Exe II ExtD 353 Exe II/ExtD

Operating temperature range -60°C +80°C

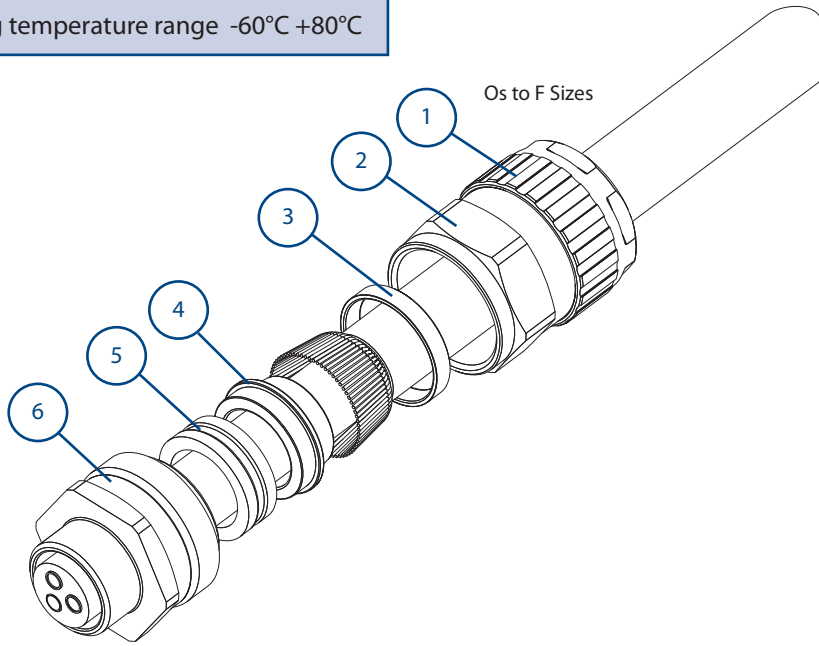

Certification Details

Gland Type: 501/453 Exd IIC/Exe II/ExtD
Baseefa06ATEX0056X Ⓢ II 2 GD A21 IP66 Ⓒ
IECEX BAS06.0013X
CEPEL-EX-061/2001X
GOST R No: POCC GB.ГБ05.В01831
CSA No: 1015065 (LR 78713-7)

Gland Type: 353 Exe II/ExtD
Baseefa06ATEX0059X Ⓢ II 2 GD A21 IP66 Ⓒ
IECEX BAS06.0016X
CSA No: 1205533 (LR 78713-10)

1. Backnut
2. Middle Nut
3. Armour Clamping Ring
4. Armour Spigot
5. Inner Seal
6. Entry (with captive deluge seal), if fitted

Cable Preparation

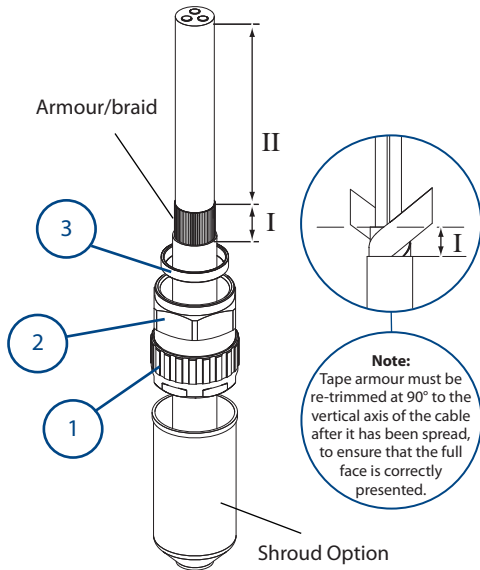

Gland Preparation

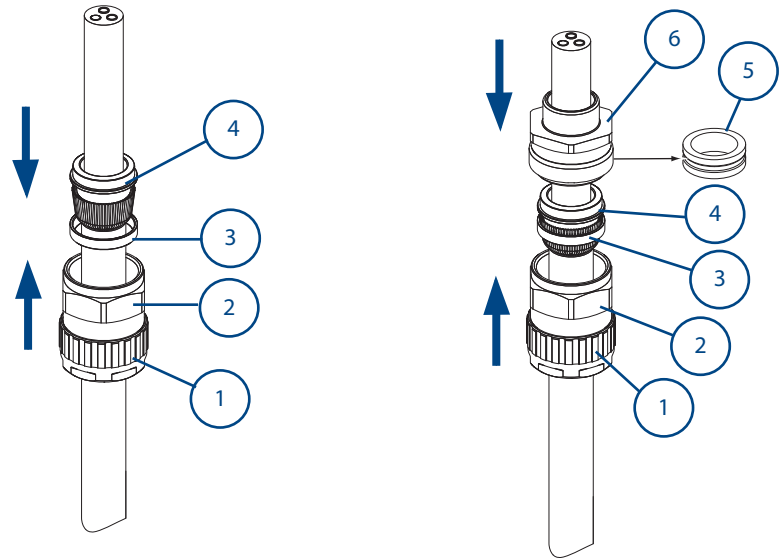

A

Strip cable to suit equipment as shown above and expose the armour/braid 'I'.

'I' = 20mm for cable gland sizes Os to C
'I' = 25mm for cable gland sizes C2 to H & J
'II' = to suit equipment.

If required, fit shroud.

B

Push the cable through the armour spigot ④. Spread armour/braid over the armour spigot ④ until the end of the armour/braid is up against the shoulder of the armour cone. Position the armour clamping ring ③.

C

Remove the inner seal ⑤ from the entry ⑥. Place the entry ⑥ over the armour spigot ④. Move the sub-assembly ① and ② up to meet the entry ⑥.

Note: If the equipment has a threaded entry, it may be advisable to screw the entry component into the equipment to prevent twisting of the cable after step D

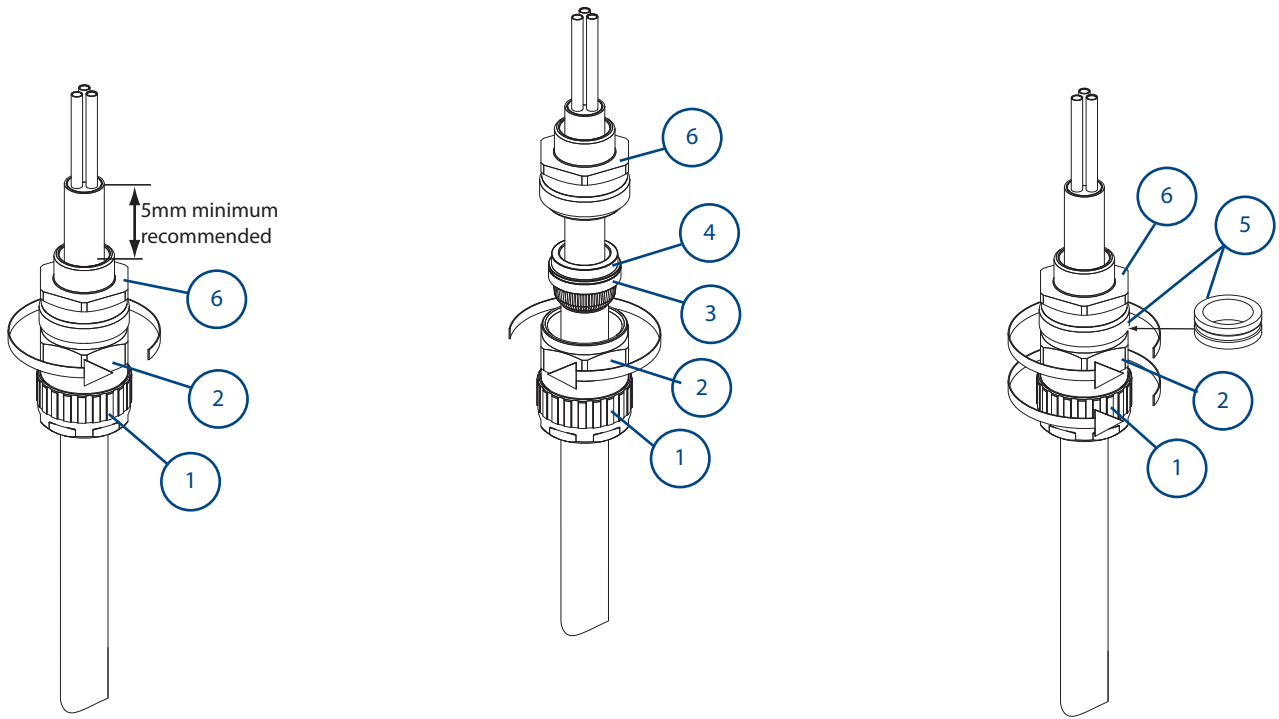

D Unless already screwed into the equipment hold the entry ⑥ in position with a spanner/wrench to prevent rotation. Hand tighten the middle nut ② to the entry ⑥ and turn a further half to one full turn with a spanner/wrench.

E Unscrew the middle nut ② and visually inspect that the armour/braid has been successfully clamped between the armour spigot ④ and the armour clamping ring ③. If armour/braid not clamped, repeat assembly.

F Remove entry ⑥ and refit inner seal ⑤, replace entry ⑥ and re-assemble middle nut ② onto the entry component ⑥. Tighten up the middle nut ② using a wrench/spanner until resistance is felt between the seal and cable, then turn the middle nut through a further half a full turn to complete the inner seal.

IMPORTANT: Support the cable to prevent it from twisting. To ease wiring inside the enclosure, it may be beneficial to strip the inner sheath of the cable as shown above.

Tighten the backnut ① to form a seal around the cable, then tighten a further full turn using a wrench/spanner. Ensure that the middle nut ② does not rotate when tightening the backnut ①. Ensure that the deluge seal is pulled down into position, if fitted.

Locate the shroud over the cable gland, if applicable.

CABLE GLAND SELECTION TABLE

Size Ref.	Entry Thread Size		Cable Acceptance Details									Max Length	Hexagon Dimensions	
			Inner Sheath				Outer Sheath		Standard Steel Wire 'W'	Wire Braid 'X'	Strip / Tape 'Z'		Across Flats	Across Corners
	Standard Seal		Alternative Seal (S)		Min.	Max.								
	Metric	NPT	Min.	Max.			Min.	Max.	Min.	Max.				
Os	M20	½"	3.0	8.0	---	---	5.5	12.0	0.8/1.25	0.2/0.35	0.2 - 0.8	76	24.0	27.7
O	M20	½"	6.5	11.9	---	---	9.5	16.0	0.8/1.25	0.2/0.35	0.2 - 0.8	76	24.0	27.7
A	M20	½" - ¾"	10.0	14.3	8.5	13.4	12.5	20.5	0.8/1.25	0.2/0.35	0.2 - 0.8	78	30.0	34.6
B	M25	¾" - 1"	12.5	20.2	9.5	15.4	16.9	26.0	1.25/1.6	0.2/0.45	0.2 - 1.0	83	36.0	41.6
C	M32	1" - 1¼"	19.0	26.5	14.5	21.2	22.0	33.0	1.6/2.0	0.2/0.45	0.2 - 1.4	87	46.0	53.1
C2	M40	1¼" - 1½"	25.0	32.5	22.0	28.0	28.0	41.0	1.6/2.0	0.3/0.45	0.2 - 1.8	94	55.0	63.5
D	M50	1½" - 2"	31.5	42.3/44.4	27.5	34.8	36.0	52.6	2.0/2.5	0.4/0.45	0.2 - 1.8	114	65.0	75.1
E	M63	2" - 2½"	42.5	54.3/56.3	39.0	46.5	46.0	65.3	2.5	0.4/0.45	0.2 - 1.8	110	80.0	92.4
F	M75	2½" - 3"	54.5	65.3/68.2	48.5	58.3	57.0	78.0	2.5	0.4/0.45	0.2 - 1.8	115	95.0	109.6

• Sizes Os and O are available with an M16 thread size. If M16 entry is used on O size cable glands the maximum cable inner sheath diameter is limited to 10.9mm.

CABLE GLAND SELECTION TABLE

Size Ref.	Entry Thread Size		Cable Acceptance Details					Max Length	Hexagon Dimensions	
			Inner Sheath		Outer Sheath		Steel Wire Armour/ Tape/Braid		Across Flats	Across Corners
	Metric	NPT	Min.	Max.	Min.	Max.				
G	M80	3½"	67.0	73.0	75.0	89.5	#	114	106.4	123.0
H	M90	3½"	67.0	77.6	75.0	89.5	#	114	115.0	132.8
J	M100	4"	75.0	91.6	88.0	104.5	#	114	127.0	146.7
* K	M110	4"	91.9	95.9	104.7	107.7	#	132.5	150.0	168.0

Dedicated armour clamping rings are fitted to order.

* Industrial gland only.

SCHEDULE OF LIMITATIONS:

- The cable glands when used with braided cable types are only suitable for use with fixed apparatus, the cable for which must be effectively clamped and cleated elsewhere.
- This cable gland has an operating temperature range of -60°C to +80°C.
- A seal must be formed between the equipment and the cable gland to maintain the appropriate degree of protection against ingress of dust, solid objects and water.

ACCESSORIES:

Before cable gland assembly or stripping of the cable gland assembly, consideration should be given to any cable gland accessories that may be required, such as: -

- Shroud, to offer additional corrosion protection.
- Locknut, to secure cable glands into position.
- Sealing washer, to offer additional ingress protection of the enclosure at the cable gland entry.
- Earthtag, to provide an external armour/braid bonding point.
- Serrated washer, to dampen any vibrations that may loosen the locknut or cable gland assembly.