

Assembly Instructions for cable gland: 501/423 Exd IIC/Exe II/ExtD

Operating temperature range -60°C +100°C

Certification Details

Gland Type: 501/423 Exd IIC/Exe II/ExtD
Baseefa06ATEX0056X  II 2 GD A21 IP66 CE
IECEX BAS06.0013X
CEPEL No: CEPEL-EX-060/2001X
CSA No: 1015065 (LR 78713-7)

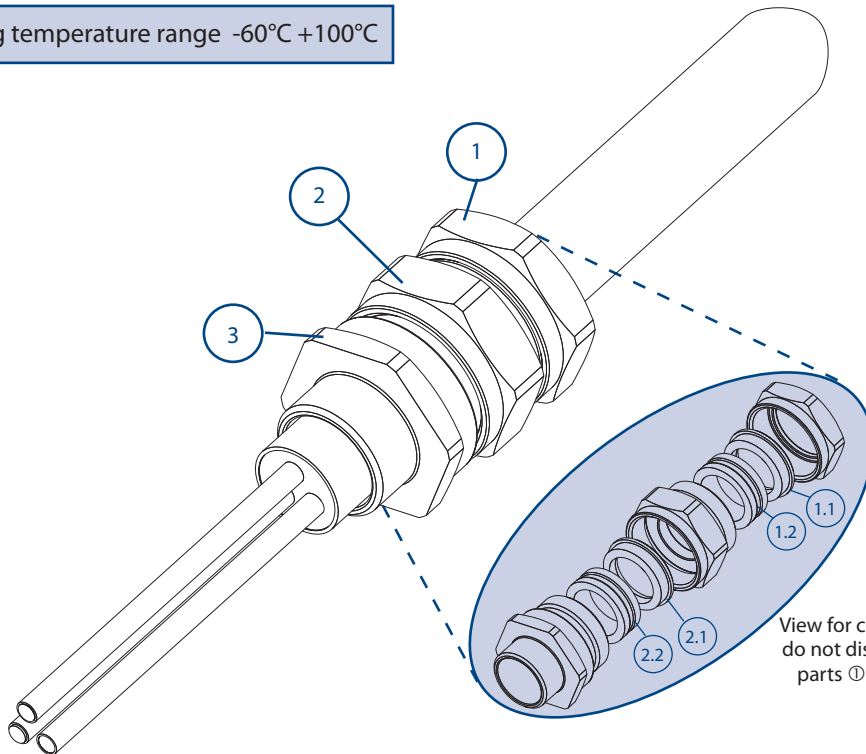

1. Backnut
 - 1.1 Compression Spigot
 - 1.2 Seal
2. Middle Nut
 - 2.1 Compression Spigot
 - 2.2 Seal
3. Entry

View for clarity only,
do not disassemble
parts ①, ② & ③.

Cable Preparation

Gland Preparation

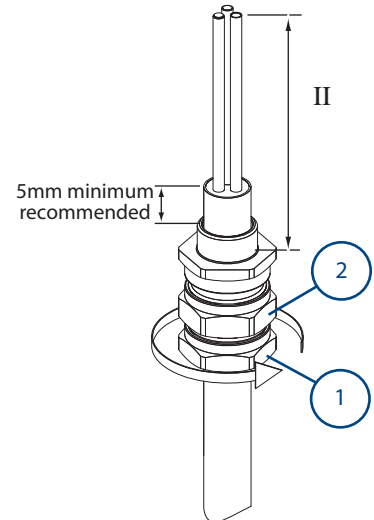
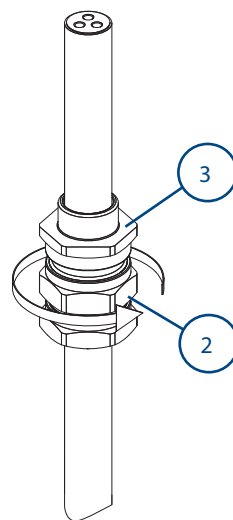
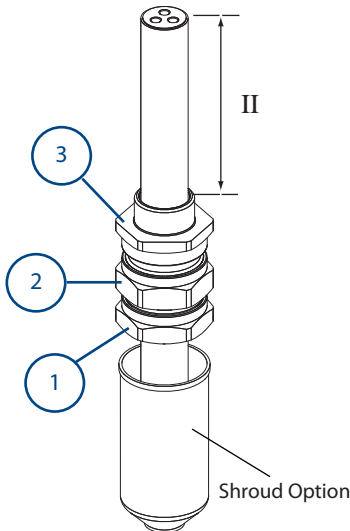

A Allow sufficient length of cable, II, to suit equipment. If required, fit shroud. Pass cable through cable gland as shown above.

Note : If the equipment has a threaded entry, it may be advisable to screw the cable gland into the equipment to prevent twisting of the cable after Step B & C.

B Unless already screwed into the equipment hold the entry ③ in position with a spanner/wrench to prevent rotation and tighten the middle nut ② using a wrench/spanner until resistance is felt between the seal and cable. Then turn the middle nut through a further half to one full turn to complete the inner seal.

C Hold the middle nut ② in position with a spanner/wrench to prevent rotation and tighten the backnut ① using a wrench/spanner until resistance is felt between the seal and cable, then turn the middle nut through a further half to one full turn to complete the outer seal. Locate the shroud over the cable gland, if applicable. To ease wiring inside the equipment it may be beneficial to strip the outer sheath of the cable, as shown above.

IMPORTANT:
Support the cable to prevent twisting.

CABLE GLAND SELECTION TABLE									
Size Ref.	Entry Thread Size		Cable Acceptance Details				Max Length	Hexagon Dimensions	
			Outer Sheath						
	Metric	NPT	Standard Seal		Alternative Seal (S)			Across Flats	Across Corners
			Min.	Max.	Min.	Max.			
Os	M20 [*]	½"	3.0	8.0	---	---	64	24.0	27.7
O	M20 [*]	½"	7.5	11.9	---	---	64	24.0	27.7
A	M20	½" - ¾"	11.0	14.3	8.5	13.4	60	30.0	34.6
B	M25	¾" - 1"	13.0	20.2	9.5	15.4	68	36.0	41.6
C	M32	1" - 1¼"	19.0	26.5	15.5	21.2	70	46.0	53.1
C2	M40	1¼" - 1½"	25.0	32.5	22.0	28.0	73	55.0	63.5
D	M50	1½" - 2"	31.5	42.3/44.4	27.5	34.8	100	65.0	75.1
E	M63	2" - 2½"	42.5	54.3/56.3	39.0	46.5	98	80.0	92.4
F	M75	2½" - 3"	54.5	65.3/68.2	48.5	58.3	100	95.0	109.6
G	M80	3½"	67.0	73.0	---	---	94	106.4	123.0
H	M90	3½"	67.0	77.6	---	---	94	115.0	132.8
J	M100	4"	75.0	91.6	---	---	94	127.0	146.7

- Sizes Os and O are available with an M16 thread size. If M16 entry is used on O size Cable Glands the maximum cable inner sheath diameter is limited to 10.9mm.

SCHEDULE OF LIMITATIONS:

1. These cable gland types are only suitable for use with fixed apparatus, the cable for which must be effectively clamped and cleated elsewhere.
2. This cable gland has an operating temperature range of -60°C to +80°C.
3. A seal must be formed between the equipment and the cable gland to maintain the appropriate degree of protection against ingress of dust, solid objects and water.

ACCESSORIES:

Before cable gland assembly or stripping of the cable gland assembly, consideration should be given to any cable gland accessories that may be required, such as: -

- Shroud, to offer additional corrosion protection.
- Locknut, to secure cable glands into position.
- Sealing washer, to offer additional ingress protection of the enclosure at the cable gland entry.
- Serrated washer, to dampen any vibrations that may loosen the locknut or cable gland assembly.