

# Assembly Instructions for cable gland: ICG 653/UNIV Exd IIC/Exe II ExtD 653/UNIV EExd I/EEEx I

Operating temperature range -60°C +80°C

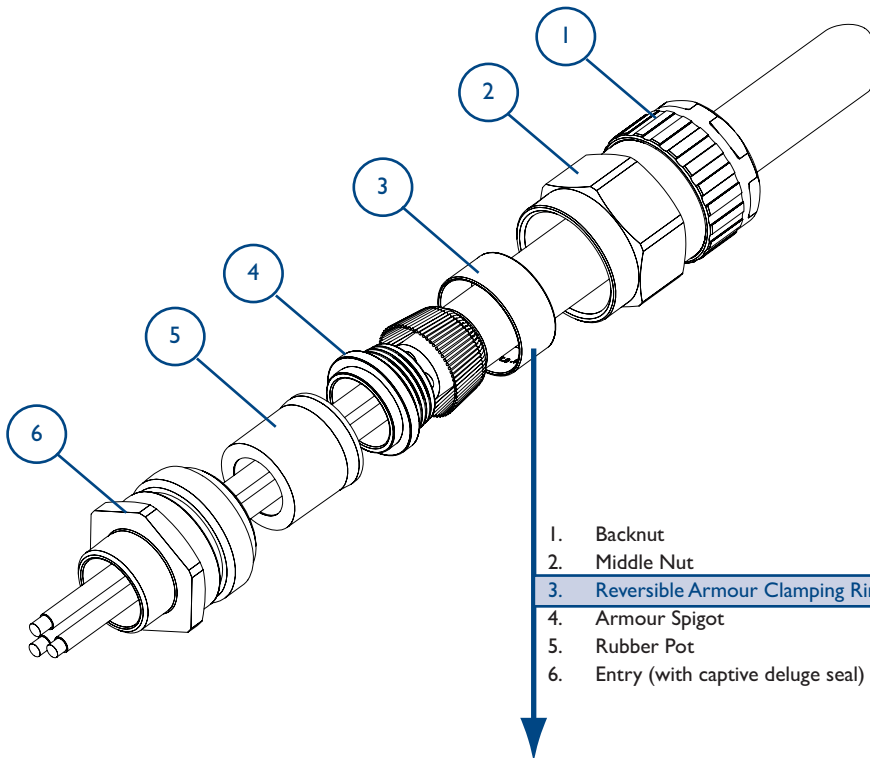

1. Backnut
2. Middle Nut
3. Reversible Armour Clamping Ring (RAC)
4. Armour Spigot
5. Rubber Pot
6. Entry (with captive deluge seal)

### Certification Details

Gland Type: ICG 653/UNIV Exd IIC/Exe II/ExtD  
Baseefa No: 06ATEX0058X Ⓢ II 2 GD A21 IP66 Ⓒ  
IECEX No: BAS06.0015X  
CEPEL No: CEPEL-EX-065/2001X  
GOST R No: POCC GB.ГБ05.В01 I 28  
CSA No: 1024328 (LR 78713-9)

Gland Type: 653/UNIV EExd I/EEEx I  
Baseefa No: 02ATEX0175X Ⓢ IM 2 IP66 Ⓒ  
IECEX No: N/A

### Reversible Armour Clamping Ring (RAC)

General identification ring orientation for:

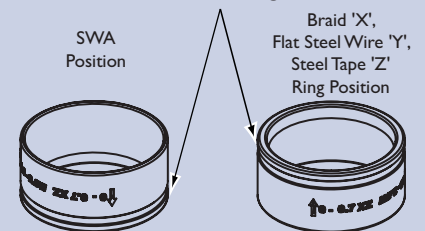

**IMPORTANT:** The arrowhead indicating the correct armour thickness or type should point towards the equipment

**Note:** Armour cable acceptance sizes are marked on the clamping ring.

### Cable Preparation

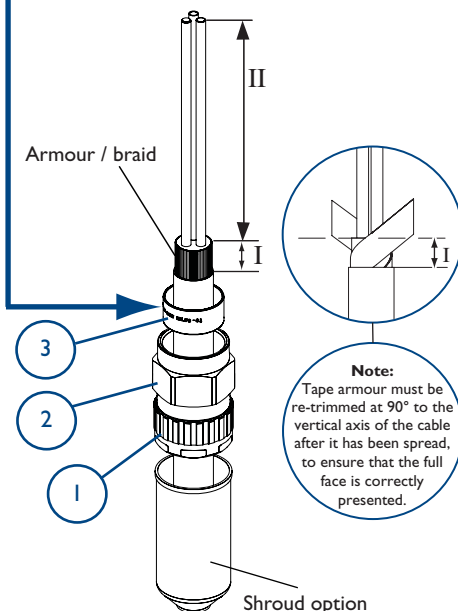

### Gland Preparation

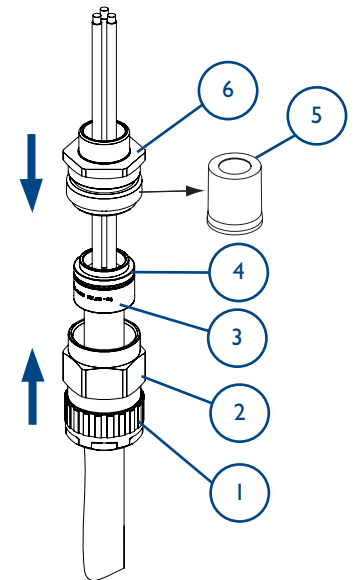
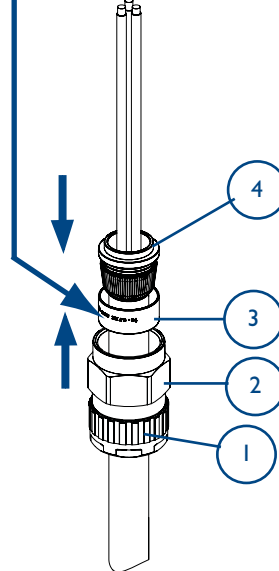

### A

Strip Cable to suit equipment as shown above and expose the armour/braid 'I' removing all cable fillers.  
'I' = 20mm for cable gland sizes Os to A  
'I' = 25mm for cable gland sizes B to C2  
'I' = 32mm for cable gland sizes D to F  
'II' to suit equipment.  
If required, fit shroud.  
See Notes re. Drain Wires.

### B

Push the cable through the armour spigot ④. Spread armour/braid over the armour spigot ④ until the end of the armour/braid is up against the shoulder of the armour cone. Position the armour clamping ring ③.

### C

Remove the rubber pot ⑤ from the entry ⑥. Place the entry ⑥ over the armour spigot ④. Move the sub-assembly ① and ② up to meet the entry ⑥.

## Safety First

Hawke International is a division of Hubbell Ltd.  
Registered No. 669157 in England. Registered Office:  
Mitre House, 160 Aldersgate Street, London EC1A 4DD.  
A member of the Hubbell Group of Companies

Hawke International  
UK Office  
Oxford Street West,  
Ashton-Under-Lyne,  
Lancashire  
OL7 0NA. UK

AI 301 - Issue L / Page 1 of 2  
Sales (UK): 0870 606 0105  
Sales: +44 (0) 161 830 6698  
Technical (UK): 0870 458 9358  
Technical: +44 (0) 161 830 6697  
Fax: +44 (0) 161 830 6648  
E-mail: sales@ehawke.com

[www.ehawke.com](http://www.ehawke.com)

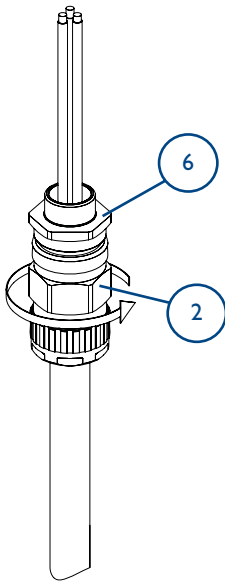

**D**  
Hold the entry ⑥ in position with a spanner/wrench to prevent rotation. Hand tighten the middle nut ② onto the entry ⑥ and turn a further ½ to ¾ of a turn with a spanner/wrench.

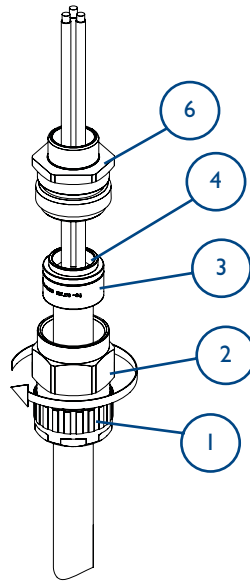

**E**  
Unscrew the middle nut ② and visually inspect that the armour/braid has been successfully clamped between the armour spigot ④ and the armour clamping ring ③. If armour/braid not clamped repeat assembly.

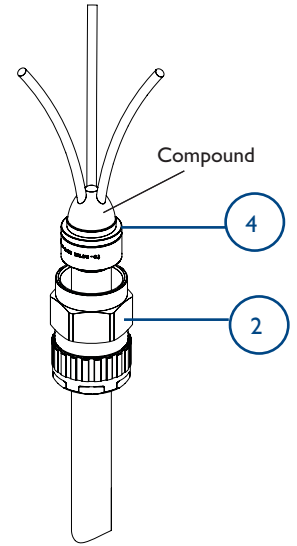

**F**  
Remove the entry ⑥, spread the cable cores out for the compound packing. Pack the compound between the cores shown. See notes below and Fig. 7 for compound preparation.

### EPOXY COMPOUND PREPARATION

When handling this material, the gloves supplied must be worn. The epoxy compound is supplied in the form of a two part package. These should be mixed into the ratio of 1:1 until both colours have blended into one, without any streaks. Rolling and folding is the most satisfactory method of obtaining an even blend. Once mixed, the compound must be used within 30 minutes. After this time it will begin to stiffen. The compound should be kept at an ambient temperature of no less than 20°C prior to using. At lower temperatures it becomes difficult to mix. Should any compound come into contact with the skin it should be cleaned off with skin cleaner and not allowed to dry on the skin. Only compound for immediate terminations should be mixed.

The mixing and installation of the compound at an ambient temperature below 4°C is not recommended due to extended curing periods.

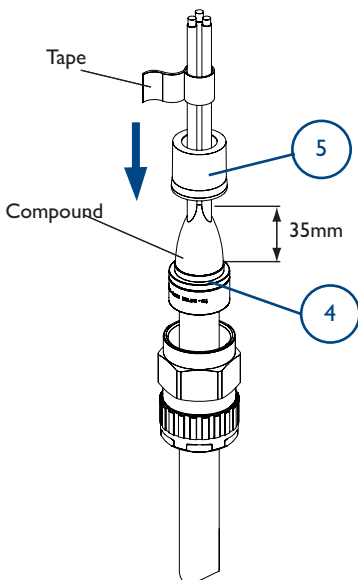

**G**  
With all gaps and voids filled, bring the conductors back together and pack more compound around the outside of the conductors. Tape the conductors together to prevent disturbance of the compound seal. Pass the rubber pot ⑤ over the armour spigot ④ and remove any surplus compound from the top of rubber pot ⑤ and the joint face as indicated.

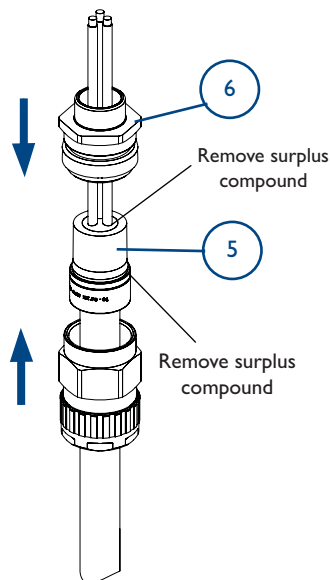

**H**  
Replace the entry ⑥ over the rubber pot ⑤ ensuring that compound does not cover the end of ⑤.

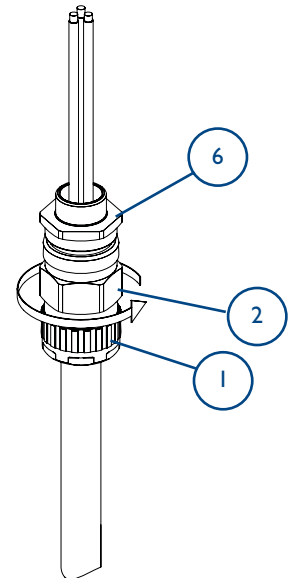

**I**  
Locate and hand tighten the sub-assembly ① and ② to the entry ⑥.

**IMPORTANT: The conductors must not be moved for a minimum of four hours.**

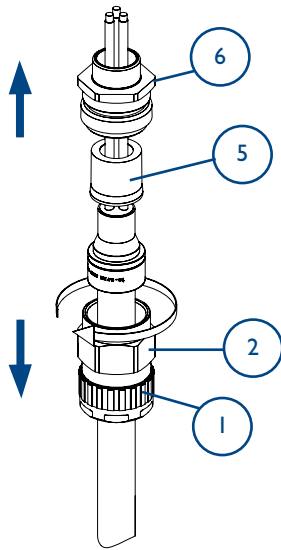

**J**  
 Allow the compound to cure. (See Fig. 7 for Curing Times). Untighten the sub-assembly ① and ② from the entry ⑥ to enable inspection. The rubber pot ⑤ may be removed for inspection to ensure that the packing is satisfactory.

Add further compound if necessary

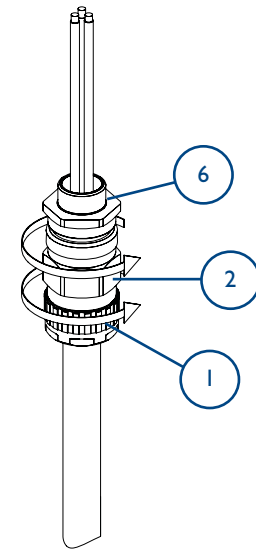

**K**  
 Re-assemble the rubber pot ⑤ and the entry ⑥. Hand tighten the sub-assembly ① and ② to the entry ⑥ and add half a turn with a spanner / wrench. Tighten the backnut ① to form a seal around the cable, then tighten a further full turn using a wrench / spanner. Ensure that the middle nut ② does not rotate when tightening the backnut. Ensure that the deluge seal is pulled down into position. Locate the shroud over the cable gland, if applicable.

*The following instructions are the various BASEEFA approved methods of passing drain wires etc. through the compound barrier and should be followed if permitted by cable installation specifications.*

## DRAIN WIRE PREPARATION

### 1.0 INSULATING DRAIN WIRES WITH HEAT SHRINK OR COLD SHRINK TUBING

- 1.1 Fold back the armour / braid and bend it to right angles from the inner sheath.
- 1.2 Remove foils and tape level with the outer sheath, exposing the drain wires and insulated conductors. Cut back a further 10mm of inner sheath.
- 1.3 Pass 100mm length of heat shrink or cold shrink tubing over the drain wire until it comes into contact with the foils, then shrink the tubing evenly down onto the drain wire so that no air pockets occur.
- 1.4 To insulate the joint between the foils and the tubing a suitable piece of 10mm long shrink tubing or neoprene stretch tubing or a 10mm wide lap of PVC tape may be used.
- 1.5 After completing 1.1 to 1.4 on each drain wire, lay the armour / braid parallel to the cable, if applicable, then carry out instruction B.

### 2.0 INSULATING DRAIN WIRES / SCREENS WITH SEPARATE INSULATED CRIMPED CONDUCTORS OR SOLDERED CONNECTION

- 2.1 Fold back the armour / braid and bend to right angles from the inner sheath.
- 2.2 Remove a further 15mm of inner sheath (See Fig. 1).
- 2.3 Unravel one or two groups of wires from the screen wires, then remove the remainder of the screen wires (See Fig. 2).
- 2.4 Twist the group of screen wires into a pigtail and cut to 15mm long.
- 2.5 Crimp an insulated conductor to the pigtail with a suitable insulated butt ferrule (or soldered connection), leaving enough length of the insulated conductor to enable the remote end to be connected to the earth terminal in the equipment. (See Fig. 3). Note: There shall be a minimum of 10mm of compound on both ends of the crimped / soldered joint.
- 2.6 To insulate the joint between the screen wires and the insulated conductor, place one lap of PVC insulating tape over the exposed metallic joint.
- 2.7 After completing 2.1 to 2.6 on each drain wire, lay the armour / braid parallel to the cable. Then carry out instruction B.

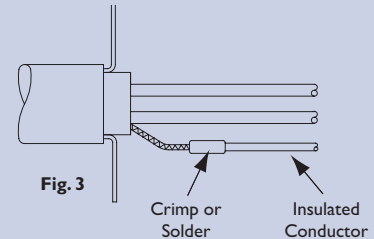
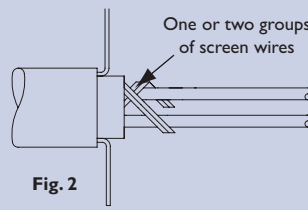
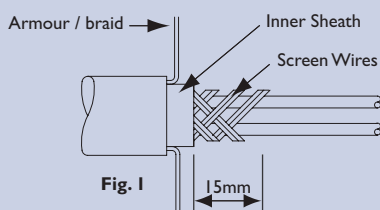

### 3.0 INSULATING DRAIN WIRES WITH INSULATING VARNISH OR PAINT

- 3.1 Fold back the armour / braid and bend it at right angles from the inner sheath.
- 3.2 Remove the foil and tape level with the inner sheath exposing the drain wires and conductor pairs.
- 3.3 Cut back a further 10mm of inner sheath (See Fig. 4).
- 3.4 Spray or paint the drain wires with insulating varnish or paint, then leave to dry (See Fig. 5)
- 3.5 To insulate the foil ends a suitable piece of 10mm long shrink tubing or neoprene stretch tubing or a 10mm wide lap of PVC tape may be used (See Fig. 6).
- 3.6 After completing 3.1 to 3.5 on each drain wire, lay the armour / braid parallel to the cable. Then carry out instruction B.

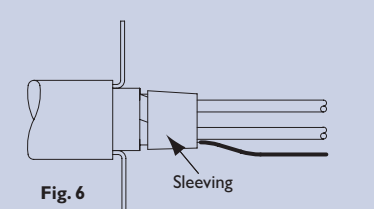
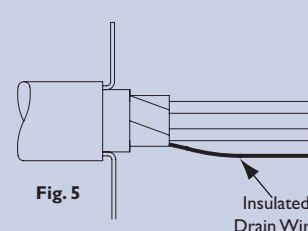
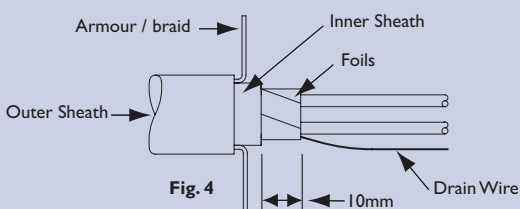

### Epoxy Compound Cure Time Vs. Temperature

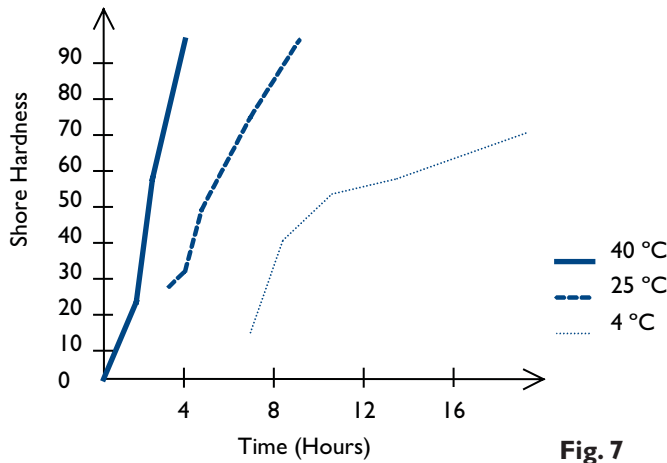

Fig. 7

- The compound may be adversely affected by some solvent vapours. If such vapours are likely to be present in the vicinity of the cable gland in service, suitable precautions may be necessary. (Contact Hawke's Technical Dept).
- The compound cures at a Shore D hardness of 85, when it can be handled. The compound when fully cured is suitable for use at a temperature range of -60°C to +80°C.

### CABLE GLAND SELECTION TABLE

Size Ref	Entry Thread Size		Cable Acceptance Details							Max. Length	Hexagon Dimensions	
			Inner Sheath/Cores			Outer Sheath		Steel Wire Armour/Tape/Braid			Across Flats	Across Corners
	Metric	NPT	Max. Over Cores	Max. Inner Sheath	Max. No. of Cores	Min.	Max.	Orientation 1	Orientation 2			
Os	M20	½"	8.9	10.0	6	5.5	12.0	0.9/1.25	0/0.7	83.0	24.0	27.7
O	M20	½"	8.9	10.0	6	9.5	16.0	0.9/1.25	0/0.7	83.0	24.0	27.7
A	M20	½" - ¾"	11.0	12.5	10	12.5	20.5	0.9/1.25	0/0.7	84.0	30.0	34.6
B	M25	¾" - 1"	16.2	18.4	21	16.9	26.0	1.25/1.6	0/0.7	91.0	36.0	41.6
C	M32	1" - 1¼"	21.9	24.7	42	22.0	33.0	1.6/2.0	0/0.7	98.0	46.0	53.1
C2	M40	1¼" - 1½"	26.3	29.7	60	28.0	41.0	1.6/2.0	0/0.7	100.0	55.0	63.5
D	M50	1½" - 2"	37.1	41.7	80	36.0	52.6	1.8/2.5	0/1.0	116.0	65.0	75.1
E	M63	2" - 2½"	47.8	53.5	100	46.0	65.3	1.8/2.5	0/1.0	124.0	80.0	92.4
F	M75	2½" - 3"	59.0	65.3/66.2	120	57.0	78.0	1.8/2.5	0/1.0	122.0	95.0	109.6

#### SCHEDULE OF LIMITATIONS:

1. This cable gland has an operating temperature range of -60°C to +80°C.
2. A seal must be formed between the equipment and the cable gland to maintain the appropriate degree of protection against ingress of dust, solid objects and water.

#### ACCESSORIES:

Before cable gland assembly or stripping of the cable gland assembly, consideration should be given to any cable gland accessories that may be required, such as: -

- Shroud, to offer additional corrosion protection.
- Locknut, to secure cable glands into position.
- Sealing washer, to offer additional ingress protection of the enclosure at the cable gland entry.
- Earthtag, to provide an external armour / braid bonding point.
- Serrated washer, to dampen any vibrations that may loosen the locknut or cable gland assembly.