

# Assembly Instructions for cable gland: 501/453/RAC Exd IIC/Exe II ExtD 353/RAC Exe II/ExtD 153/RAC Industrial General Purpose

Operating temperature range -60°C +80°C

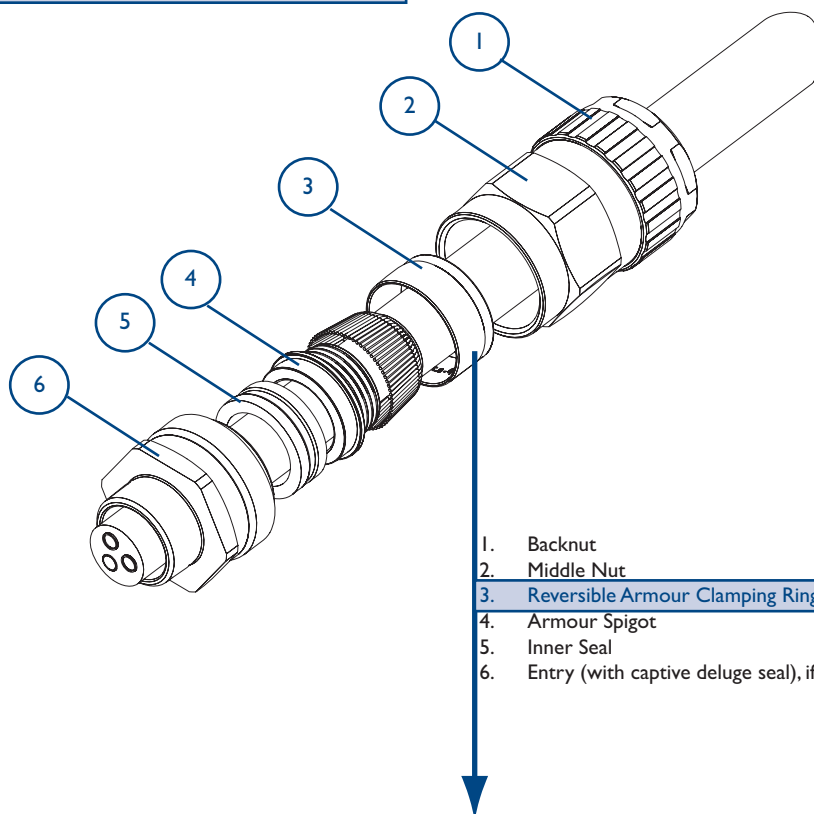

1. Backnut
2. Middle Nut
3. Reversible Armour Clamping Ring (RAC)
4. Armour Spigot
5. Inner Seal
6. Entry (with captive deluge seal), if required

### Certification Details

Gland Type: 501/453/RAC Exd IIC/Exe II/ExtD  
Baseefa No: 06ATEX0056X Ⓢ II 2 GD A21 IP66 Ⓢ  
IECEX No: BAS06.0013X  
CEPEL No: CEPEL-EX-062/2001X  
GOST R No: POCC GB.ГБ05.Б01 I 28  
CSA No: 1015065 (LR 78713-10)

Gland Type: 353/RAC Exe II/ExtD  
Baseefa No: 06ATEX0059X Ⓢ II 2 GD A21 IP66 Ⓢ  
IECEX No: BAS06.0016X  
CSA No: 1205533 (LR 78713-10)

Gland Type: 153/RAC Industrial  
Certified to Hawke Approved Drawings Only

### Reversible Armour Clamping Ring (RAC)

General identification ring orientation for:

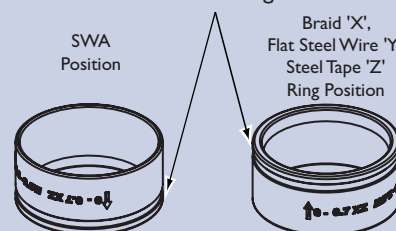

**IMPORTANT:** The arrowhead indicating the correct armour thickness or type should point towards the equipment

**Note:** Cable acceptance sizes are marked on the diaphragm seal, clamping ring and backnut.

### Cable Preparation

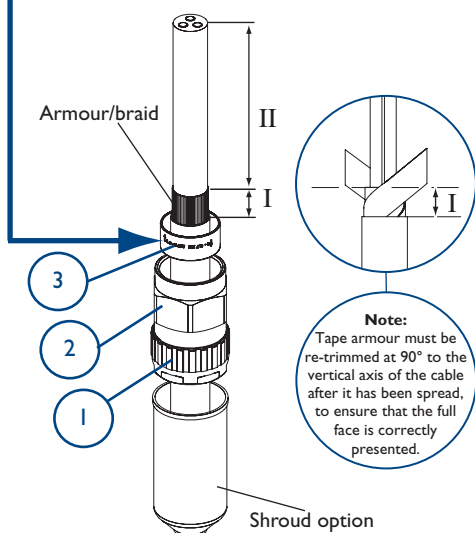

### Gland Preparation

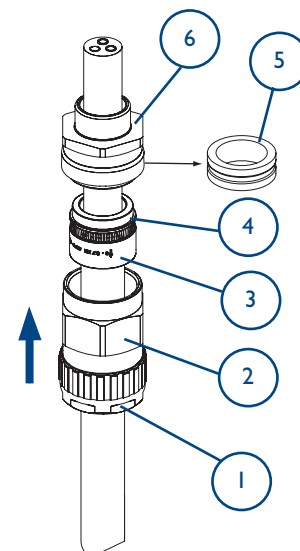
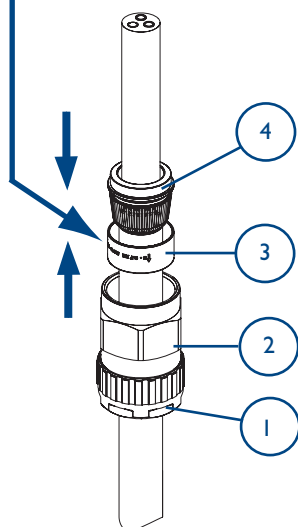

**A** Strip Cable to suit equipment as shown above and expose the armour/braid 'I'.  
'I' = 20mm for cable gland sizes Os to C  
'I' = 25mm for cable gland sizes C2 to F  
'II' = to suit equipment.  
If required, fit shroud.

**B** Push the cable through the armour spigot ④. Spread armour/braid over the armour spigot ④ until the end of the armour/braid is up against the shoulder of the armour cone. Position the armour clamping ring ③.

**C** Remove the inner seal ⑤ from the entry ⑥. Place the entry ⑥ over the armour spigot ④. Move the sub-assembly ① and ② up to meet the entry ⑥.

**Note:** If the equipment has a threaded entry, it may be advisable to screw the entry component into the equipment to prevent twisting of the cable after step D

## Safety First

Hawke International is a division of Hubbell Ltd.  
Registered No. 669157 in England. Registered Office:  
Mitre House, 160 Aldersgate Street, London EC1A 4DD.  
A member of the Hubbell Group of Companies

Hawke International  
UK Office  
Oxford Street West,  
Ashton-Under-Lyne,  
Lancashire  
OL7 0NA, UK

AI 302 - Issue L / Page 1 of 3  
Sales (UK): 0870 606 0105  
Sales: +44 (0) 161 830 6698  
Technical (UK): 0870 458 9358  
Technical: +44 (0) 161 830 6697  
Fax: +44 (0) 161 830 6648  
E-mail: sales@ehawke.com

[www.ehawke.com](http://www.ehawke.com)

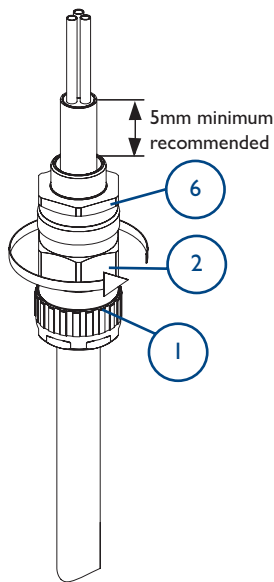

**D**  
Unless already screwed into the equipment hold the entry ⑥ in position with a spanner/wrench to prevent rotation. Hand tighten the middle nut ② to the entry ⑥ and turn a further 1/2 to 3/4 of a turn with a spanner/wrench.

**IMPORTANT:** Support the cable to prevent it from twisting. To ease wiring inside the enclosure, it may be beneficial to strip the inner sheath of the cable as shown above.

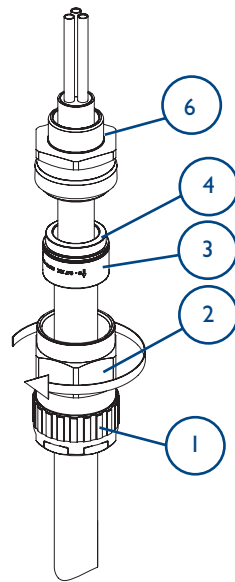

**E**  
Unscrew the middle nut ② and visually inspect that the armour/braid has been successfully clamped between the armour spigot ④ and the armour clamping ring ③. If armour/braid not clamped, repeat assembly.

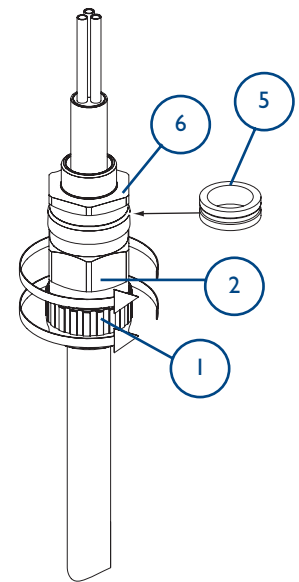

**F**  
Remove entry ⑥ and refit inner seal ⑤, replace entry ⑥ and re-assemble middle nut ② onto the entry component ⑥. Tighten up the middle nut ② using a wrench/spanner until resistance is felt between the seal and cable, then turn the middle nut through a further half a full turn to complete the inner seal.

Tighten the backnut ① to form a seal around the cable, then tighten a further full turn using a wrench/spanner. Ensure that the middle nut ② does not rotate when tightening the backnut ①. Ensure that the deluge seal is pulled down into position, if fitted.

Locate the shroud over the cable gland, if applicable.

## CABLE GLAND SELECTION TABLE

Size Ref.	Entry Thread Size		Cable Acceptance Details								Max Length	Hexagon Dimensions	
			Inner Sheath				Outer Sheath		Steel Wire Armour/ Tape/Braid				
	Metric	NPT	Standard Seal		Alternative Seal (S)				Orientation 1	Orientation 2			
			Min.	Max.	Min.	Max.	Min.	Max.				Across Flats	Across Corners
Os	M20*	½"	3.0	8.0	---	---	5.5	12.0	0.9/1.25	0/0.7	79	24.0	27.7
O	M20*	½"	6.5	11.9	---	---	9.5	16.0	0.9/1.25	0/0.7	79	24.0	27.7
A	M20	½" - ¾"	10.0	14.3	8.5	13.4	12.5	20.5	0.9/1.25	0/0.7	79	30.0	34.6
B	M25	¾" - 1"	12.5	20.2	9.5	15.4	16.9	26.0	1.25/1.6	0/0.7	95	36.0	41.6
C	M32	1" - 1¼"	19.0	26.5	14.5	21.2	22.0	33.0	1.6/2.0	0/0.7	95	46.0	53.1
C2	M40	1¼" - 1½"	25.0	32.5	22.0	28.0	28.0	41.0	1.6/2.0	0/0.7	98	55.0	63.5
D	M50	1½" - 2"	31.5	42.3/44.4	27.5	34.8	36.0	52.6	1.8/2.5	0/1.0	126	65.0	75.1
E	M63	2" - 2½"	42.5	54.3/56.3	39.0	46.5	46.0	65.3	1.8/2.5	0/1.0	130	80.0	92.4
F	M75	2½" - 3"	54.5	65.3/68.2	48.5	58.3	57.0	78.0	1.8/2.5	0/1.0	128	95.0	109.6

- \* Sizes Os and O are available with an M16 thread size. If M16 entry is used on O size cable glands the maximum cable inner sheath diameter is limited to 10.9mm.

## EN 50262 CABLE GLAND CLASSIFICATION

Cable Gland Type	Material			Mechanical Properties				Electrical Properties				External Influences			Sealing System	
	Metal	Non-Metallic	Composite	Without Cable Anchorage	With Cable Anchorage	Impact Category	Cable Retention (Armoured Cable)	Equipotential Bonding	Connection to Metallic Layers	Protective Connection to Earth	Insulation Characteristics	Ingress Protection	Temperature Range	Resistance to Salt and Sulphur Dioxide Laden Atmospheres	Single Orifice Seal	Multi-Orifice Seal
153	Y			X	A	8	B	Y	Y	C	X	Y	Y	Y	Y	X

### SCHEDULE OF LIMITATIONS:

- The cable glands when used with braided cable types are only suitable for use with fixed apparatus, the cable for which must be effectively clamped and cleated elsewhere.
- This cable gland has an operating temperature range of -60°C to +80°C.
- A seal must be formed between the equipment and the cable gland to maintain the appropriate degree of protection against ingress of dust, solid objects and water.

### ACCESSORIES:

Before cable gland assembly or stripping of the cable gland assembly, consideration should be given to any cable gland accessories that may be required, such as:-

- Shroud, to offer additional corrosion protection.
- Locknut, to secure cable glands into position.
- Sealing washer, to offer additional ingress protection of the enclosure at the cable gland entry.
- Earthtag, to provide an external armour / braid bonding point.
- Serrated washer, to dampen any vibrations that may loosen the locknut or cable gland assembly.