

Assembly Instructions for cable gland: 501/421 Exd IIC/Exe II/ExtD 321 Exe II/ExtD 121 Industrial General Purpose

HAWKE International

Assembly Instructions
AI 307 / Issue L - 08/06

Operating temperature range -60°C +100°C

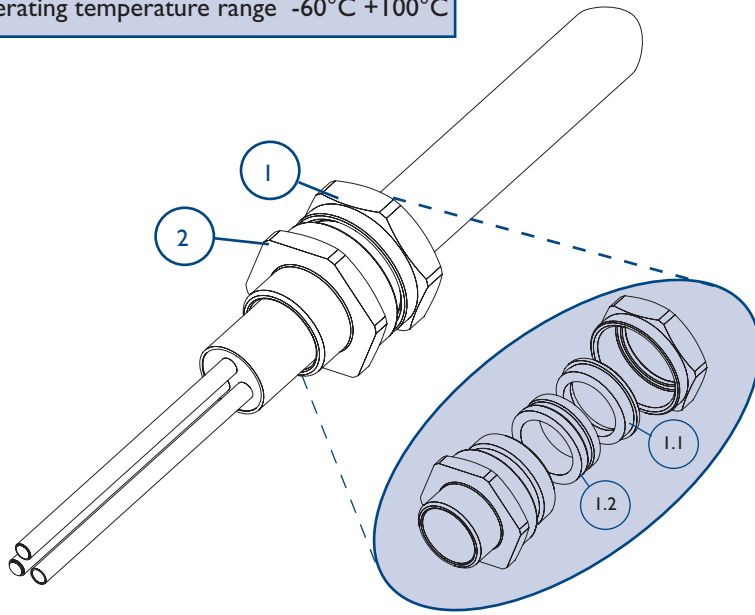

Certification Details

Gland Type: 501/421 Exd IIC/Exe II/ExtD
Baseefa No: 06ATEX0056X Ⓢ II 2 GD A21 IP66 Ⓢ
IECEX No: BAS06.0013X
CEPEL No: CEPEL-EX-059/2001X
GOST R No: POCC GB.ГБ05.Б01 I 28
CSA No: 1015065 (LR 78773-7)

Gland Type: 321 Exe II/ExtD
Baseefa No: 06ATEX0059X Ⓢ II 2 GD A21 IP66 Ⓢ
IECEX No: BAS06.0016X
CSA No: 1205533 (LR 78713-10)

Gland Type: 121 Industrial
Certified to Hawke Approved Drawings Only

- 1. Backnut
- 1.1 Compression Spigot
- 1.2 Seal
- 2. Entry

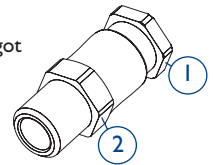

421/2K size only.
View for clarity only,
do not disassemble ① & ②.

Cable Preparation

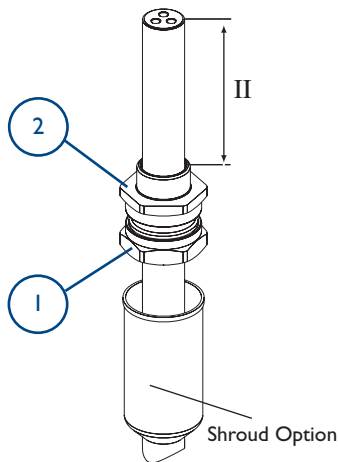

A
Allow sufficient length of cable, II, to suit equipment.
If required, fit shroud.
Pass cable through the cable gland as shown above.

Note : If the equipment has a threaded entry, it may be advisable to screw the cable gland into the equipment to prevent twisting of the cable after Step B

Gland Preparation

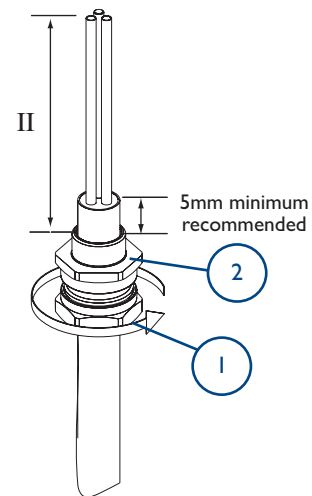

B
Unless already screwed into the equipment, hold the entry ② in position with a spanner/wrench to prevent rotation and tighten the backnut ① using a wrench/spanner until resistance is felt between the seal and cable. Then turn the back nut through a further half a full turn to complete the inner seal. Locate the shroud over the cable gland, if applicable.

To ease wiring inside the equipment it may be beneficial to strip the outer sheath of the cable as shown above.

IMPORTANT: Support the cable to prevent it from twisting

Safety First

Hawke International is a division of Hubbell Ltd.
Registered No. 669157 in England. Registered Office:
Mitre House, 160 Aldersgate Street, London EC1A 4DD.
 A member of the Hubbell Group of Companies

Hawke International
UK Office
Oxford Street West,
Ashton-Under-Lyne,
Lancashire
OL7 0NA, UK

AI 307 - Issue L / Page 1 of 2
Sales (UK): 0870 606 0105
Sales: +44 (0) 161 830 6698
Technical (UK): 0870 458 9358
Technical: +44 (0) 161 830 6697
Fax: +44 (0) 161 830 6648
E-mail: sales@ehawke.com

www.ehawke.com

CABLE GLAND SELECTION TABLE									
Size Ref.	Entry Thread Size		Cable Acceptance Details				Max Length	Hexagon Dimensions	
			Outer Sheath						
	Metric	NPT	Standard Seal		Alternative Seal (S)			Across Flats	Across Corners
			Min.	Max.	Min.	Max.			
2K	M16	---	3.0	8.0	---	---	39	19.0	21.2
Os	M20*	1/2"	3.0	8.0	---	---	38	24.0	27.7
O	M20*	1/2"	7.5	11.9	---	---	39	24.0	27.7
A	M20	1/2" - 3/4"	11.0	14.3	8.5	13.4	38	30.0	34.6
B	M25	3/4" - 1"	13.0	20.2	9.5	15.4	41	36.0	41.6
C	M32	1" - 1 1/4"	19.0	26.5	15.5	21.2	43	46.0	53.1
C2	M40	1 1/4" - 1 1/2"	25.0	32.5	22.0	28.0	44	55.0	63.5
D	M50	1 1/2" - 2"	31.5	42.3/44.4	27.5	34.8	61	65.0	75.1
E	M63	2" - 2 1/2"	42.5	54.3/56.3	39.0	46.5	59	80.0	92.4
F	M75	2 1/2" - 3"	54.5	65.3/68.2	48.5	58.3	60	95.0	109.6
G	M80	3 1/2"	67.0	73.0	---	---	54	106.4	123.0
H	M90	3 1/2"	67.0	77.6	---	---	54	115.0	132.8
J	M100	4"	75.0	91.6	---	---	54	127.0	146.7

- Sizes Os and O are available with an M16 thread size. If M16 entry is used on O size Cable Glands the maximum cable inner sheath diameter is limited to 10.9mm.

EN 50262 CABLE GLAND CLASSIFICATION																
Cable Gland Type	Material			Mechanical Properties				Electrical Properties				External Influences			Sealing System	
	Metal	Non-Metallic	Composite	Without Cable Anchorage	With Cable Anchorage	Impact Category	Cable Retention (Armoured Cable)	Equipotential Bonding	Connection to Metallic Layers	Protective Connection to Earth	Insulation Characteristics	Ingress Protection	Temperature Range	Resistance to Salt and Sulphur Dioxide Laden Atmospheres	Single Orifice Seal	Multi-Orifice Seal
				Type	Category	Class			Category		IP66	-60° to 80°				
121	Y			X	A	8	X	Y	X	X	X	Y	Y	Y	Y	X

SCHEDULE OF LIMITATIONS:

1. The cable glands are only suitable for use with fixed apparatus, the cable for which must be effectively clamped and cleated elsewhere.
2. This cable gland has an operating temperature range of -60°C to +80°C.
3. A seal must be formed between the equipment and the cable gland to maintain the appropriate degree of protection against ingress of dust, solid objects and water.