

PROTECTA III

Ex e FLUORESCENT

IEC Ex
ZONE 1 APPLICATIONS

The Protecta III luminaire for tubular fluorescent lamps is rugged and high quality.

It is constructed using a glass reinforced polyester (GRP) body and polycarbonate diffuser which resist saline and other corrosive environments.

Major features of the luminaire are the strength of the enclosure and mounting points together with the very high degree of ingress protection afforded by the simple reliable construction.

All the control gear is mounted on a gear tray.

The ease of access to lamps and control gear ensures that installation and maintenance will be completed quickly and efficiently.



Standard Specification

Type of Protection:	Ex eqm (Increased safety Powder filling Encapsulation)
Area Classification:	Zone 1 and 2 areas to IEC 60079-10, IEC 61241-3 with installation to IEC 60079-14, IEC 61241-1-2
Apparatus Standard:	IEC 60079-0, 60079-7, 60079-17, 60079-18, 61241-1-1
Certificate:	IEC Ex ITS 03.0005
Coding:	Ex eqm II T4 Tamb 55°C
Enclosure:	GRP body with polycarbonate cover and brass suspension points
Reflector/Geartray:	White polyester painted zinc coated steel
Entry:	4 x M20 cable entries, 2 at each end
Termination:	3 core 6mm ² max. conductor with looping and 16A rating through wiring
Installation:	Two M8 tapped brass inserts located on rear of body.
Control Gear:	High Frequency
Relamping:	Quick release diffuser clamp and hinged cover
Lampholder:	G13 (Bi-pin)
Lamp Type:	T8 tubular fluorescent
Burning Position:	Universal
Ingress Protection:	IP66/67 to IEC 60529
Electrical Supply	220V - 254V 50/60Hz 220 - 300V dc

Features

- Simple rugged construction
- Full length easy access diffuser clamp
- Hinged cover
- Standard fixing centres
- High frequency control gear gives 50/60Hz operation, high power factor correction and regulation of lamp output
- Automatic lamp de-energisation on opening
- Screwless mains terminals
- Shell/ERA deluge tested
- Resistant to voltage fluctuations
- Vibration tested to comply with Lloyds/DNV
- Gost Approved
- Cepel Approved



United Kingdom	Tel:- +44 (0) 141 882 5555	Fax:- +44 (0) 141 883 3704	Email:- info@chalmit.com
Benelux	Tel: +31 (0)302 467 132	Fax: +31 (0) 302 467 133	Email: john.van.straalen@planet.nl
Abu Dhabi	Tel: +971 2621 3496	Fax: +971 2631 2152	Email: rwood@emirates.net.ae
Singapore	Tel: +65 451 4484	Fax: +65 451 1411	Email: chalmits@singnet.com.sg

Std. Cat No.	Part No.	Wattage	Weight
PRGE/218/BI	500231	2x18W	4.2kg
PRGE/136/BI	500331	1x36W	9.6kg
PRGE/236/BI	500431	2x36W	9.8kg
PRGE/258/BI	500831	2x58W	12.0kg
PRGE/218/MO	500239	2x18W	4.2kg
PRGE/136/MO	500339	1x36W	9.6kg
PRGE/236/MO	500439	2x36W	9.8kg
PRGE/258/MO	500839	2x58W	12.0kg

**MO - Mono-pin Lamps
Mono-pin Coding; Ex eqd IIC**

Options Suffix to Catalogue No.

/120	Specific voltage (110/120)
/SE	Spigot entry 18W only
/M25	M25 Entries
/3P	3 phase termination facility (Not available if looping required)
/EL	Extra live termination facility (to match emergency circuit)
/SB	Stainless steel mounting bush
/D	Dust Protected Zone 21 (In combination with Zone 1 gas version)

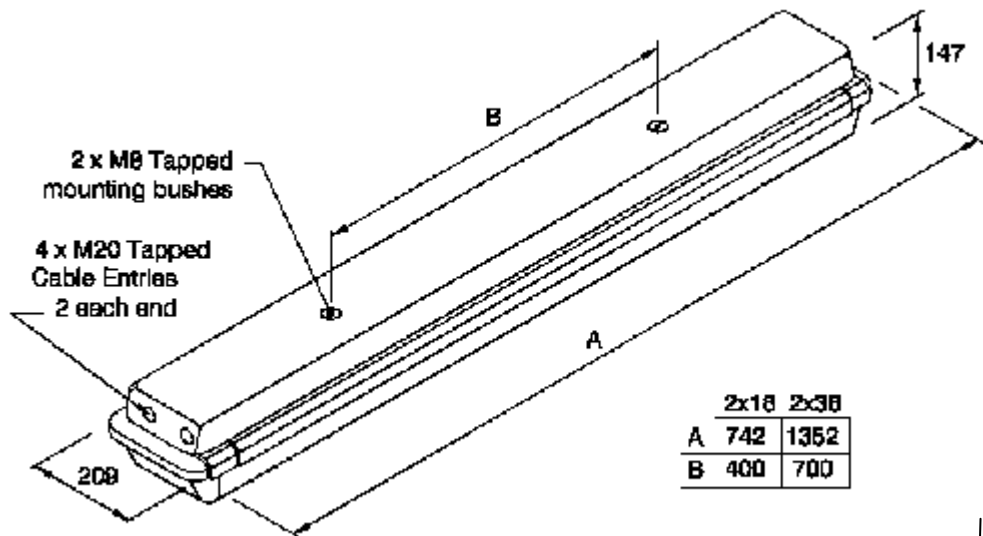

	2x18	2x36	2x58
A	742	1352	1650
B	400	700	700

Accessories (Should be ordered separately)

Catalogue Order Code

Offset ceiling bracket assembly	SPRO4-0002
Pole mounting bracket assembly (38/50 diameter poles)	SPRO4-0003
C' form hook type ceiling bracket assembly	SPRO4-0005
Flush mounted wall bracket assembly	SPRO4-0006
Wall mounting outreach bracket (18W spigot entry version)	NPRO4-0007
18W wall mounting outreach bracket (use with SPRO4-0003)	NPRO4-0008
36W wall mounting outreach bracket (use with SPRO4-0003)	NPRO4-0012
Eyebolt set	SPRO5-0005
Looping Kit (Allows looping from both ends of luminaire)	SPROT-0021



United Kingdom Tel:- +44 (0) 141 882 5555
 Benelux Tel: +31 (0)302 467 132
 Abu Dhabi Tel: +971 2621 3496
 Singapore Tel: +65 451 4484

Fax:- +44 (0) 141 883 3704
 Fax: +31 (0) 302 467 133
 Fax: +971 2631 2152
 Fax: +65 451 1411

Email:- info@chalmit.com
 Email: john.van.straalen@planet.nl
 Email: rwood@emirates.net.ae
 Email: chalmits@singnet.com.sg