

PROTECTA III

STAINLESS STEEL

Ex e FLUORESCENT

IEC Ex ZONE 1 APPLICATIONS

The Protecta III luminaire for tubular fluorescent lamps is also made with a stainless steel body. This version shares the technical features of the GRP bodied range being rugged and technically advanced. The emergency version has comprehensive self testing and an internal battery with all the control gear mounted together on a gear tray.

Protecta Stainless has excellent durability as it is constructed using 316S31 stainless steel and a polycarbonate diffuser.

The product is intended for applications where chemical agents which could attack GRP are present.

The strong, simple and reliable enclosure affords a high degree of ingress protection. The ease of access to lamps and control gear ensures that installation and maintenance will be completed quickly and efficiently.



Standard Specification

Type of Protection:	Ex eqm (Increased safety Powder filling Encapsulation)
Area Classification:	Zone 1 and Zone 2 areas to IEC 60079-10 with installation to IEC 60079-14
Apparatus Standard:	IEC 60079-0, 60079-7, 60079-17, 60079-18, 61241-1-1
Certificate:	IEC Ex ITS 03.0005
Coding:	Ex eqm II T4 Tamb 55°C (45°C for emergency version)
Enclosure:	Stainless steel 316S31 body with polycarbonate cover
Reflector/Geartray:	White polyester painted zinc coated steel
Entry:	4 x M20 cable entries, 2 at each end
Termination:	3 core 6mm ² max. conductor with looping and 16A rating through wiring (4 core for emergency)
Installation:	Two M8 tapped stainless steel inserts located on rear of body
Lampholder:	G13 (Bi-pin)
Lamp Type:	T8 tubular fluorescent
Control Gear:	High Frequency
Relamping:	Quick release diffuser clamps and hinged cover
Burning Position:	Universal
Ingress Protection:	IP66 to IEC 60529
Electrical Supply:	220V - 254V 50/60Hz, and 220V - 300V dc non-emergency only
Battery:	Internal Ni-Cd Battery (6V 4 Ah)
Duration:	90 minutes to IEC 60598-2-22
Emergency Output:	30% of one lamp (18W), 25% of one lamp (36W)

Features

- Simple rugged construction
- Hinged cover with easily removeable cover clamps
- Standard fixing centres
- High frequency control gear gives 50/60Hz operation, high power factor correction and regulation of lamp output
- Automatic lamp de-energisation on opening
- Screwless mains terminals
- Resistance to voltage fluctuations
- Battery management, monitoring and automatic self test
- dc operation (non-emergency only)
- Ability to detect and indicate impending end of emergency lamp life before actual failure
- Gost Approved



United Kingdom	Tel:- +44 (0) 141 882 5555	Fax:- +44 (0) 141 883 3704	Email:- info@chalmit.com
Benelux	Tel: +31 (0)302 467 132	Fax: +31 (0) 302 467 133	Email: john.van.straalen@planet.nl
Abu Dhabi	Tel: +971 2621 3496	Fax: +971 2631 2152	Email: rwood@emirates.net.ae
Singapore	Tel: +65 451 4484	Fax: +65 451 1411	Email: chalmits@singnet.com.sg

Std. Cat No.	Part No.	Wattage	Weight
PRSE/218/BI	510231	2x18W	6.0kg
PRSE/136/BI	510331	1x36W	8.2kg
PRSE/236/BI	510431	2x36W	9.6kg
PRSE/258/BI	510831	2x58W	11.8kg
PRSE/218/BI/EM	512231	2x18W	9.1kg
PRSE/236/BI/EM	512431	2x36W	12.5kg
PRSE/218/MO	510239	2x18W	6.0kg
PRSE/136/MO	510339	1x36W	8.2kg
PRSE/236/MO	510439	2x36W	9.6kg
PRSE/258/MO	510839	2x58W	11.8kg
PRSE/218/MO/EM	512239	2x18W	9.1kg
PRSE/236/MO/EM	512439	2x36W	12.5kg

Options - Suffix to Catalogue No.

/120	120V
/M25	M25 Entries
/3P	3 phase termination facility (Not available if looping required)
/EL	Extra live termination facility (compatible with 4 core switched emergency circuits)
/D	Dust Protected Zone 21 (In combination with Zone 1 gas version)
/3H	3 hour battery duration

MO - Mono-pin lamps
Mono-pin coding: Ex eqd IIC
Mono-pin emergency coding: Ex eqdm IIC

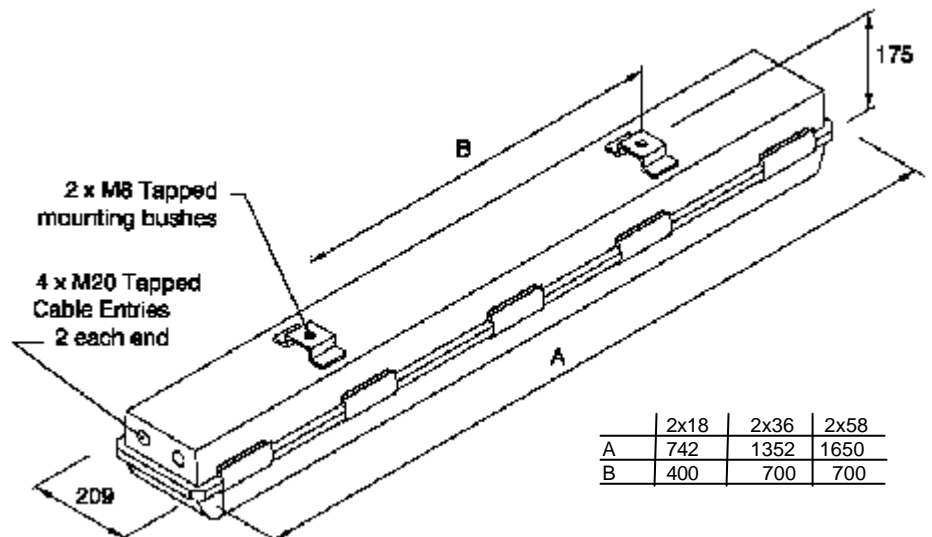

Accessories (Should be ordered separately)

Catalogue Order Code

Offset ceiling bracket assembly kit	SPRO4-0002
Pole mounting bracket assembly (38/50mm diameter poles)	SPRO4-0003
C' form hook type ceiling bracket assembly kit	SPRO4-0005
Flush mounted wall bracket assembly kit	SPRO4-0006
18W wall mounting outreach bracket (use with SPRO4-0003)	NPRO4-0008
36W wall mounting outreach bracket (use with SPRO4-0003)	NPRO4-0012
Eyebolt kit	SPRO5-0005
Looping kit (allows looping from both ends of luminaire)	SPROT-0021
Remote Ex switch for emergency inhibition (1 switch controls up to 10 luminaires)	SPROT-0033



United Kingdom	Tel:- +44 (0) 141 882 5555	Fax:- +44 (0) 141 883 3704	Email:- info@chalmit.com
Benelux	Tel: +31 (0)302 467 132	Fax: +31 (0) 302 467 133	Email: john.van.straalen@planet.nl
Abu Dhabi	Tel: +971 2621 3496	Fax: +971 2631 2152	Email: rwood@emirates.net.ae
Singapore	Tel: +65 451 4484	Fax: +65 451 1411	Email: chalmits@singnet.com.sg