

PROTECTA III E

Ex e EMERGENCY FLUORESCENT

IEC Ex ZONE 1 APPLICATIONS

The Protecta III emergency luminaire for tubular fluorescent lamps is rugged, technically advanced and high quality. It incorporates comprehensive self testing and an internal battery with the control gear mounted on a gear tray.

The emergency light output and duration is outstanding. Protecta is constructed using a glass reinforced polyester (GRP) body and polycarbonate diffuser which resist saline and other corrosive environments. Major features of the luminaire are the strength of the enclosure and mounting points together with the very high degree of ingress protection afforded by the simple reliable construction.

The ease of access to lamps and control gear means that installation and maintenance will be completed quickly and efficiently.



Standard Specification

Type of Protection:	Ex eqm (Increased safety Powder filling Encapsulation)
Area Classification:	Zone 1 and 2 areas to IEC 60079-10, IEC 61241-3 with installation to IEC 60079-14, IEC 61241-1-2
Apparatus Standard:	IEC 60079-0, 60079-7, 60079-17, 60079-18, 61241-1-1
Certificate:	IEC Ex ITS 03.0005
Coding:	Ex eqm II T4 Tamb 55°C
Enclosure:	GRP body with polycarbonate cover and brass suspension points
Reflector/Geartray:	White polyester painted zinc coated steel
Entry:	4 x M20 cable entries, 2 at each end
Termination:	4 core 6mm ² max. conductor with looping and 16A rating through wiring
Installation:	Two M8 tapped brass inserts located on rear of body
Control Gear:	High Frequency
Relamping:	Quick release diffuser clamp and hinged cover
Lampholder:	G13 (Bi-pin)
Lamp Type:	T8 tubular fluorescent
Burning Position:	Universal
Ingress Protection:	IP66/67 to IEC 60529
Electrical Supply:	220V - 254V 50/60Hz
Battery:	Internal Ni-Cd Battery (6V 4 Ah)
Duration:	90 minutes to IEC 60598-2-22
Emergency Output:	30% of one lamp (18W), 25% of one lamp (36W)

Features

- Battery management, monitoring and automatic self test
- Simple rugged construction
- Full length easy access diffuser clamp
- Standard fixing centres
- High frequency control gear gives 50/60Hz operation, high power factor correction and regulation of lamp output
- Automatic lamp de-energisation on opening
- Screwless mains terminals
- Shell/ERA deluge tested
- Vibration tested to comply with Lloyds/DNV
- Resistant to voltage fluctuations
- Emergency inhibition and mains power off re-start
- Ability to detect and indicate impending end of emergency lamp life before actual failure
- Gost Approved
- Cepel Approved



United Kingdom Tel:- +44 (0) 141 882 5555
Benelux Tel: +31 (0)302 467 132
Abu Dhabi Tel: +971 2621 3496
Singapore Tel: +65 451 4484

Fax:- +44 (0) 141 883 3704
Fax: +31 (0) 302 467 133
Fax: +971 2631 2152
Fax: +65 451 1411

Email:- info@chalmit.com
Email: john.van.straalen@planet.nl
Email: rwood@emirates.net.ae
Email: chalmits@singnet.com.sg

Std. Cat No.	Part No.	Wattage	Weight
PRGE/218/BI/EM	502231	2x18W	8.3kg
PRGE/236/BI/EM	502431	2x36W	12.4kg
PRGE/218/MO/EM	502239	2x18W	8.3kg
PRGE/236/MO/EM	502439	2x36W	12.4kg

MO - Mono-pin lamps
Mono-pin coding: Ex eqdm II

Options - Suffix to Catalogue No.	
/120	Specific voltage (110/120)
/M25	M25 Entries
/RI	Remote emergency inhibition facility (External switch ordered separately)
/3P	3 phase termination facility (Not available if looping required)
/SB	Stainless steel mounting bush
/D	Dust Protected Zone 21 (In combination with Zone 1 gas version)
/3H	3 hour battery

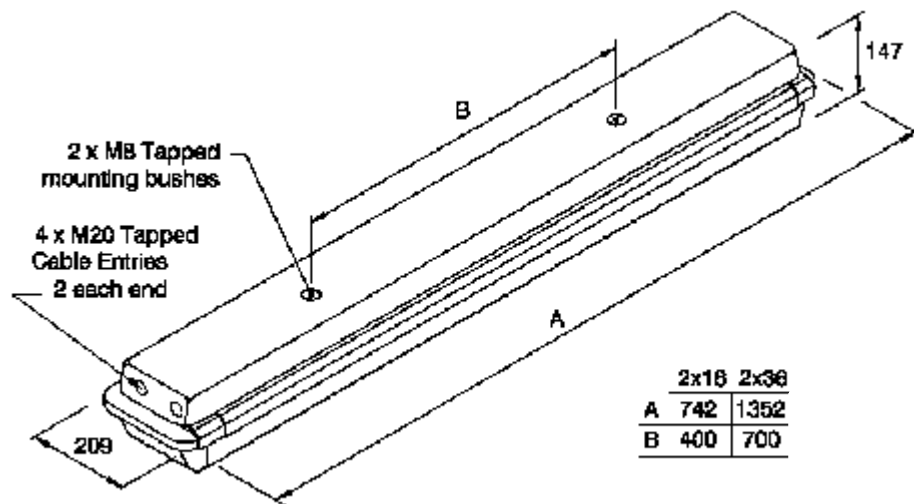

Accessories (Should be ordered separately)

Catalogue Order Code

Offset ceiling bracket assembly kit	SPRO4-0002
Pole mounting bracket assembly (38/50mm diameter poles)	SPRO4-0003
C' form hook type ceiling bracket assembly kit	SPRO4-0005
Flush mounted wall bracket assembly kit	SPRO4-0006
18W wall mounting outreach bracket (use with SPRO4-0003)	NPRO4-0008
36W wall mounting outreach bracket (use with SPRO4-0003)	NPRO4-0012
Eyebolt set	SPRO5-0005
Looping Kit (Allows looping from both ends of luminaire)	SPROT-0021
Remote Ex switch for emergency inhibition (1 switch controls up to 10 luminaires)	SPROT-0033



United Kingdom	Tel:- +44 (0) 141 882 5555	Fax:- +44 (0) 141 883 3704	Email:- info@chalmit.com
Benelux	Tel: +31 (0)302 467 132	Fax: +31 (0) 302 467 133	Email: john.van.straalen@planet.nl
Abu Dhabi	Tel: +971 2621 3496	Fax: +971 2631 2152	Email: rwood@emirates.net.ae
Singapore	Tel: +65 451 4484	Fax: +65 451 1411	Email: chalmits@singnet.com.sg