

ACCLAIM III

Ex e RECESSIBLE

IEC Ex ZONE 1 APPLICATIONS

The Acclaim range of luminaires for fluorescent lamps is available in standard and emergency versions. It is designed for use in offshore accommodation areas and for the pharmaceutical industry where it provides working, emergency and escape lighting.

Manufactured from zinc coated sheet steel the luminaire is suitable for installation in fire resistant ceilings up to SOLAS B15 rating.

The polycarbonate diffuser is available in clear, prismatic or with a glare control louvre. The mounting and cover details are flexible to allow luminaires to be recessed into a variety of ceiling types.

The control gear and batteries are mounted internally on a gear tray and access for lamp replacement and maintenance is simple and easy. The emergency version has excellent light output and duration in accordance with emergency lighting standards. Comprehensive self-testing periodically confirms the availability of sufficient emergency duration.



Standard Specification

Type of Protection:	Ex eqm (Increased safety Powder filling Encapsulation)
ATEX Classification:	Zone 1 and Zone 2 areas to IEC 60079-10 and 61241-3 with installation to IEC 60079-14 and 61241-1-2
Apparatus Standard:	IEC 60079-0, 60079-7, 60079-17, 60079-18, 61241-1-1
Certificate:	IEC Ex ITS 03-0006
Coding:	Ex eqm II T4 Tamb 55°C
Enclosure:	White polyester painted zinc coated steel body and frame Silicone rubber gasket. Clear polycarbonate diffuser
Reflector/Geartray:	White polyester painted zinc coated steel
Entry:	3 x 20mm holes, two at one end and one at the other end
Termination:	3 core 6mm ² max conductor with looping and through wiring facility (4 core on emergency)
Installation:	Fixed side brackets with swing out arms, with provision for rod mounting
Lampholder:	G13 (Bi pin)
Lamp Type:	T8 tubular fluorescent
Control Gear:	High Frequency
Relamping:	Via front cover, secured by pan head slotted screws
Burning Position:	Horizontal
Ingress Protection:	IP65 to IEC 60529
Electrical Supply:	220V - 254V 50/60Hz and 220V - 300V dc non-emergency only
Battery:	Internal Ni-Cd battery (6V 4 Ah)
Duration:	90 minute to IEC 60598-2-22
Emergency Output:	30% of one lamp (18W), 25% of one lamp (36W)

Features

- Suitable for various ceiling types
- Automatic lamp de-energisation on opening
- Screwless mains terminals
- Battery management, monitoring and automatic self test
- Resistant to voltage fluctuations
- Local switching arrangement as standard
- Ingress protection to IP65
- Electronic control gear gives 50/60Hz operation, high power factor correction and regulation of lamp output
- 3 hour emergency duration
- B15 SOLAS fire rating
- Lloyds fire rating approval for specific ceiling types supplied on request
- Emergency inhibition and power off re-start



United Kingdom Tel:- +44 (0) 141 882 5555
Benelux Tel: +31 (0)302 467 132
Abu Dhabi Tel: +971 2621 3496
Singapore Tel: +65 451 4484

Fax:- +44 (0) 141 883 3704
Fax: +31 (0) 302 467 133
Fax: +971 2631 2152
Fax: +65 451 1411

Email:- info@chalmit.com
Email: john.van.straalen@planet.nl
Email: rwood@emirates.net.ae
Email: chalmits@singnet.com.sg

Std. Cat No.	Wattage	Weight
ACLE/218/BI	2 x 18W	16kg
ACLE/236/BI	2 x 36W	23kg
ACLE/218/BI/EM	2 x 18W	19kg
ACLE/236/BI/EM	2 x 36W	26kg

Options - Suffix to Catalogue No.

/120	Specific voltage (110/120)
/25	25mm Entries
/RI	Remote emergency inhibition facility (external switch ordered separately)
/3P	3 phase termination facility (not available if through wiring required)
/EL	Extra live termination facility (compatible with 4 core (switched) emergency circuits)
/LG	Low glare louvre
/PD	Prismatic diffuser
/PC	Plasterboard (solid plank) ceiling <i>Note: Ceiling type must be stated at time of enquiry/order</i>
/3H	3 hour battery duration

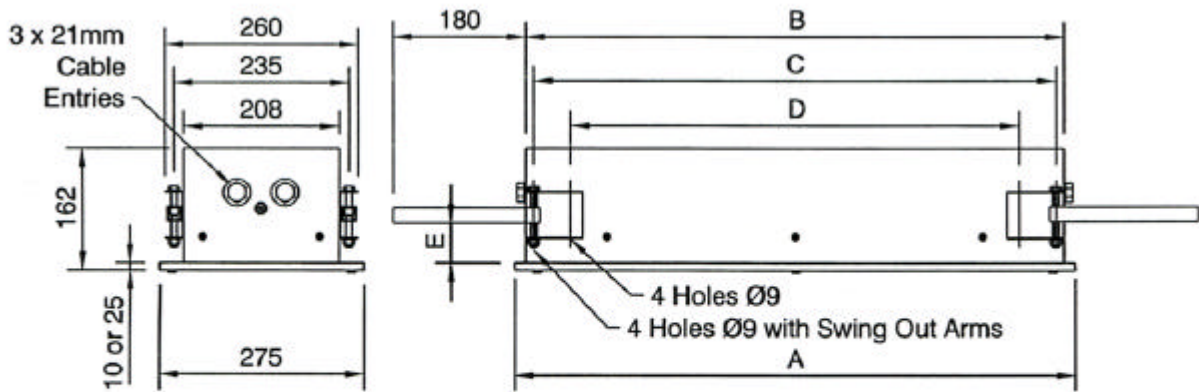

	A	B	C	D	E 10mm Cover	E 25mm Cover
2 x 18W	750	720	699	601	35 to 70	20 to 55
2 x 36W	1365	1335	1314	1216		



United Kingdom	Tel:- +44 (0) 141 882 5555	Fax:- +44 (0) 141 883 3704	Email:- info@chalmit.com
Benelux	Tel: +31 (0)302 467 132	Fax: +31 (0) 302 467 133	Email: john.van.straalen@planet.nl
Abu Dhabi	Tel: +971 2621 3496	Fax: +971 2631 2152	Email: rwood@emirates.net.ae
Singapore	Tel: +65 451 4484	Fax: +65 451 1411	Email: chalmits@singnet.com.sg